

VORTEX
THE FORCE OF OPTICS®

VIPER[®] PST[™]

RIFLESCOPE



Second Focal Plane

I-4x24 TMCQ RETICLE (MOA)

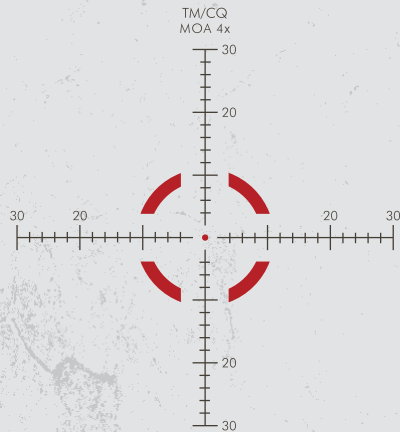

THE VORTEX[®] TMCQ[™] MOA RETICLE

Designed to maximize the performance of the Viper[®] PST[™] 1-4x24 in close and mid-range shooting situations, the TMCQ[™] MOA reticle can also be used to effectively determine ranges, holdovers, windage corrections and moving target leads. Once the Viper PST 1-4x24 rifle scope has been sighted-in and the turret caps indexed (see the rifle scope owner's manual), it is ready to be used in the field.

The following suggestions are based on using the TMCQ MOA reticle on an AR-15 style rifle chambered in most popular 5.56 mm loads and sighted in at 100 yards. If you are using a different rifle and ammunition, your results will differ somewhat, but the basic information will still apply.

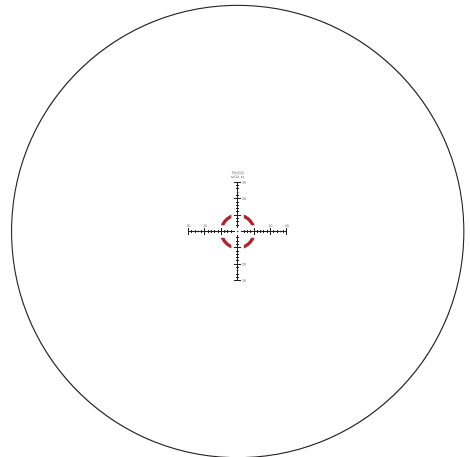

Note: Reticle images shown in this manual are for representation only—images vary between scope models depending on magnification and reticle plane.

Using at Close Ranges

At short range distances inside of 25 yards, maximum performance will come from using the PST 1-4x24 riflescope set down to lowest 1x magnification and shooting with both eyes open using the heavy outer circle and illuminated center crosshair dot to quickly center the target. On most centerfire applications, actual point-of-impact will be just below the crosshair intersection—typically 1–2 inches low from 0–25 yards.

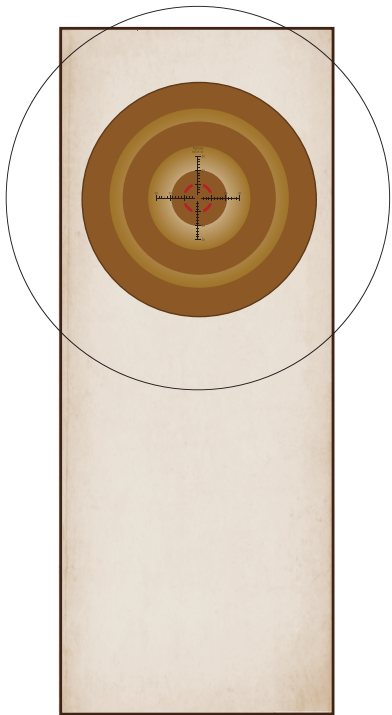

Using at Intermediate Ranges

For distances of 50–175 yards, more magnification may be used if desired and main crosshairs should still be used in a dead-on hold. On most centerfire applications, point-of-impact will typically be .2 inches below the crosshair intersection at 50 yards, dead on at 100 yards and 2.4 inches below crosshair intersection by 175 yards.

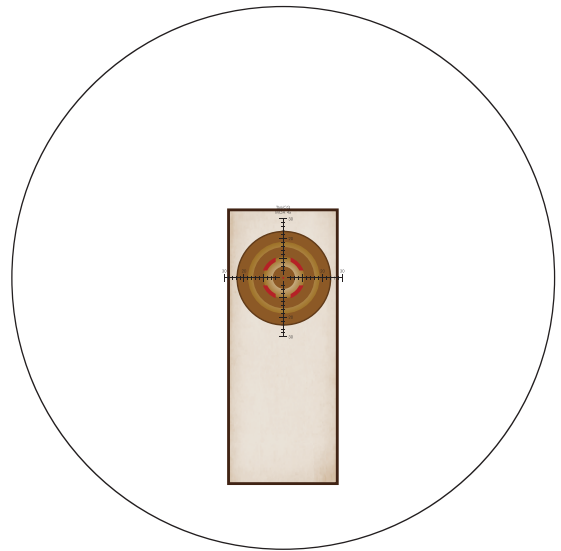

Using at Long Ranges

Once distances approach 200 yards and beyond, the reticle subtenion lines can be utilized to compensate for bullet drop. If necessary, reticle subtenions can also be used to help estimate range.

MOA Adjustments

The TMCQ MOA reticle is based on minute-of-angle (MOA) subtenions. MOA measurements are based on degrees and minutes (360 degrees in a circle and 60 minutes in a degree for a total of 21,600). These angular measurements are used to estimate range and correct for bullet trajectory drop in riflescopes. 1 MOA will correspond to 1.05 inches at a 100 yard distance, 2.1 inches at 200 yards, 3.15 inches at 300 yards, and so on. The Viper PST 1-4x uses 1/2 MOA clicks which subtend .52 inches per click at 100 yards.

TMCQ Reticle MOA Subtenions

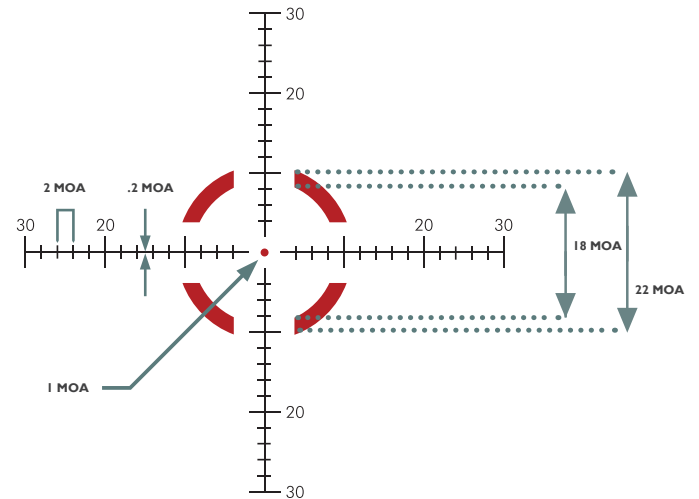

Note: When used in the second focal plane PST 1-4x24 rifle scope, the MOA subtenions listed in the diagram are *only* valid at the 4x magnification. On these riflescopes, all ranging and holdover corrections using the reticle subtenions should be done at 4x.

Ranging

The TMCQ MOA reticle can be used for approximate range estimations using a simple formula. To use this formula, it will be necessary to know the size of the target or a nearby object in inches.

Begin by turning the 1-4x24 rifle scope to a magnification of 4x. Using the inner crosshair with listed MOA dimensions (see subtension diagram), match up to target object and estimate the number of MOAs spanned by the object (see example).

Maximum accuracy in ranging will be obtained by calculating MOA measurements as closely as possible and will depend on a very steady hold. The rifle should be solidly braced using a rest, bipod or sling when measuring.

MOA Ranging Formula

$$\frac{\text{Target Size (Inches)} \times 100}{\text{MOAs Measured}} = \text{Range (Yards)}$$

Note: In the above MOA ranging formula, 100 has been substituted for the technically correct 95.5 in the interest of speedier calculations. Be aware that this will produce a five percent *over-estimation error* of the yardage distance obtained. If maximum ranging accuracy is preferred, use 95.5 instead of 100 in the formula.

Example

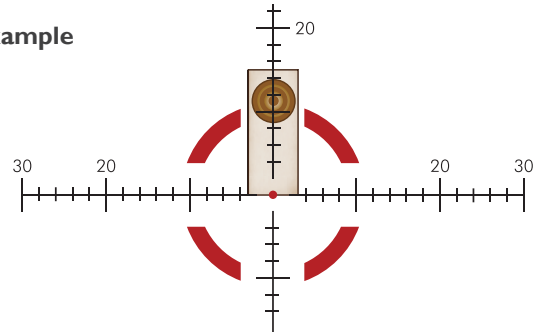

Ranging a 6-foot target (72 inches) at 15 MOAs yields 480 yards.

$$\frac{72 \times 100}{15 \text{ MOA}} = 480 \text{ Yards}$$

The inner heavy circle can also be used as a quick ranging reference. If the inner heavy circle spans half a 6-foot target's height, it will be approximately 200 yards away. If the standing target completely spans the inside of the circle, it will be approximately 400 yards away. If the target only fits inside half of the inner circle, it will be approximately 800 yards away.

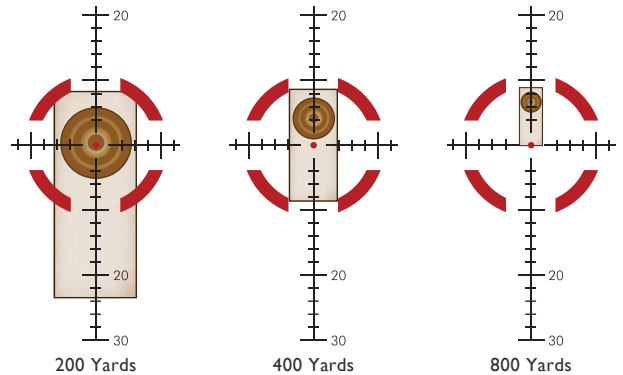

Holdovers

Once the distance has been calculated using the TMCQ MOA reticle or a laser rangefinder, the TMCQ MOA can be used for rapid holdover correction for bullet drop of the cartridge being used. To get the most benefit out of the TMCQ MOA equipped riflescope, Vortex Optics highly recommends shooters learn their bullet drop numbers in MOAs rather than inches. Since the TMCQ MOA reticle is scaled in 2 MOA increments, it is an easy job to quickly select the correct drop reference line once the shooter knows their bullet drops in MOAs. If the shooter prefers to dial their *come ups* for bullet drop using the elevation knob, knowing bullet drops in MOAs rather than inches will allow for much faster adjustments as the MOAs can be quickly read on the elevation knob.

Example

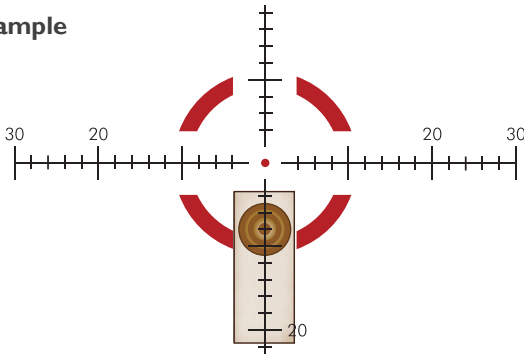

8 MOA holdover for 5.56 mm at 400 yards.

Example of a Custom MOA Drop Chart for 5.56 mm with 55 gr. FMJBT Bullets at 3000 fps MV

RANGE (Yards)	DROP (Moa)
25	-2.8
50	-0.4
75	0.1
100	-0.0
125	-0.3
150	-0.7
175	-1.2
200	-1.7
225	-2.3
250	-3.0
275	-3.7
300	-4.4
325	-5.2
350	-6.1
375	-7.0
400	-8.0
425	-9.1
450	-10.2
475	-11.4
500	-12.7
525	-14.1
550	-15.5
575	-17.1
600	-18.7
625	-20.5
650	-22.4
675	-24.4
700	-26.5
725	-28.7
750	-31.0
775	-33.5
800	-36.1

Note: Data for other cartridges and loads will vary from what is provided in this chart. Charts like this are easily generated by using the Vortex LRBC at www.vortexoptics.com.



Windage and Moving Targets

The TMCQ MOA reticle can also be used for wind and moving target leads. Using the reticle for effective windage and moving target leads will require thorough knowledge of your weapons system's ballistic performance under varying conditions and experience in reading wind strengths and target speeds. As in bullet drops, it is important for the shooter to learn their particular weapon's windage/moving target corrections in MOAs rather than inches.

Whether dialing elevation *come ups* or using the reticle subtensions for holdover, the center horizontal crosshair can be used for windage or moving lead corrections. MOA marks on the horizontal crosshair are graduated in 2 MOA increments.

Example

Reticle Correction for Wind with Elevation Correction Dialed into Turret

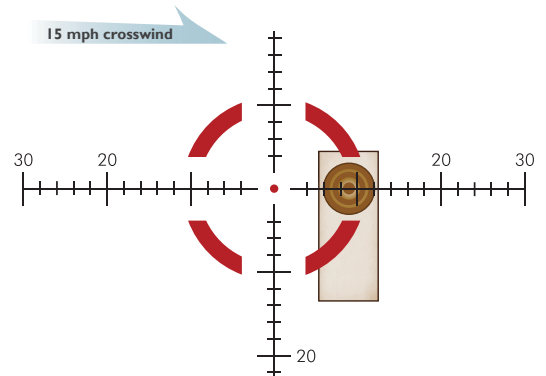

9 MOA windage correction for 5.56 mm in 15 mph crosswind at 400 yards. Elevation correction dialed into turret.

Example

Reticle Correction for Both Elevation and Wind

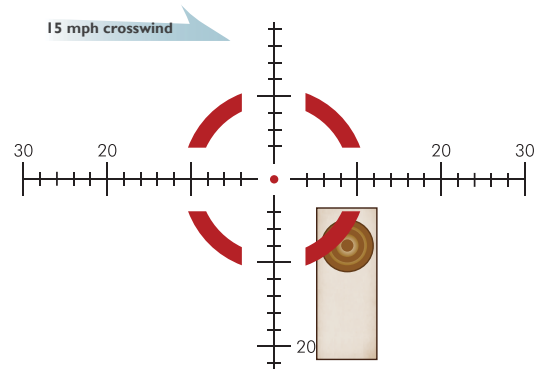

8 MOA holdover and 9 MOA windage correction for 5.56 mm in 15 mph crosswind at 400 yards.



THE VIP WARRANTY

We build optics based on our commitment to your absolute satisfaction. That's why Vortex products are unconditionally guaranteed and we make this Very Important Promise to you—a Very Important Person.

Rest assured that in the event your Viper PST becomes damaged or defective, Vortex Optics will repair or replace the riflescope at no charge to you. Call Vortex Optics at 800-426-0048 for prompt, professional, and friendly service.



Vortex Optics
2120 West Greenview Drive
Middleton, WI 53562
service@vortexoptics.com

Visit www.vortexoptics.com for more information. Canadian customers may visit www.vortexcanada.net for customer service information.

Note: The VIP warranty does not cover theft, loss, or deliberate damage to the product.

VORTEX
THE FORCE OF OPTICS®

VIPER[®] PST[™]
RIFLESCOPE



WWW.VORTEXOPTICS.COM

#PSTR14ST-A-12A

© Vortex Optics USA